



Pad



CONNECTINGS



# SYMBOLS AND FINISHES LEGEND

## SYMBOLS



= SHELF SAFELY LOCKED DURING TRANSPORTATION AND AT HOME.



= ANTI-TURNOVER LOCKING SYSTEM



= NORMS / PATENTS



= PHILLIPS / POZIDRIV



= NEWTON



= PART.NO



= HEXAGONAL SOCKET



= FRICTION



= PCS. PER PACKAGE



= BLADE SLOT



= AUTOMATIC



= COMBI SLOT



= DROP DOWN



= CAPACITY LOADING



= COUNTERSUNK HEAD



= WOOD / GLASS THICKNESS



= PAN HEAD



= STANDARD HINGE



= HOLE DIAMETER



= FLANGE HEAD



= KIMANA HINGE



= DIAMETER



= FLAT HEAD



= FLAP HINGE



= LENGTH



= TRILOBULAR SCREW



= WITH SPRING



= HEIGHT



= SELF-TAPPING SCREW



= WITHOUT SPRING



= RIGHT VERSION



= EURO THREAD



= REVERSED SPRING



= LEFT VERSION



= METRIC THREAD



= SETTING CODE



= PRE-INSERTED SCREW



= FOR ROUND TUBE



= PCS. PER PAD



= PRE-INSERTED SCREW AND SPREADING BUSH



= FOR OVAL TUBE



= CUT ON REQUEST



= WITH BUFFER



= SELF ADHESIVE



= WITH MAGNET



= WITH FLANGE

NOTE: Printing errors and omissions may exist despite our best efforts to ensure accuracy. We reserve the right to alter specifications without notice.

## MATERIALS

<b>ZA</b> = Zinc Alloy	<b>ST</b> = Steel	<b>HSS</b> = High Speed Steel	<b>BR</b> = Brass	<b>ABS</b> = Acrylonitrile Butadiene Styrene
<b>ZAnk</b> = Nickel-plated Zinc Alloy	<b>STzk</b> = Zinc-plated Steel	<b>AL</b> = Aluminium	<b>WD</b> = Wood	<b>EVA</b> = Ethylene Vinyl Acetate

<b>EP</b> = <b>ENGINEERING PLASTIC</b>	+ <b>EP</b> = other engineering plastic available on request	<b>SR</b> = <b>SOFT RUBBER</b>	+ <b>SR</b> = other soft rubber available on request
--	--	--------------------------------	--

<b>EPn</b> = Natural Engineering Plastic	<b>EPc</b> = Clear Engineering Plastic	<b>SRn</b> = Natural Soft Rubber
<b>EPw</b> = White Engineering Plastic	<b>EPg</b> = Grey Engineering Plastic	<b>SRw</b> = White Soft Rubber
<b>EPwg</b> = Water Green Engineering Plastic		<b>SRb</b> = Black Soft Rubber



## FINISHES



+ OTHER FINISHES AVAILABLE ON REQUEST

PART. NO	FINISHES	PART. NO	FINISHES	PART. NO	FINISHES
AA	Natural	IJ	Light Grey	RO	Red
AB	White	IL	Grey 20	PZ	Beech
AC	Opal White	IN	Grey met. 26	QB	Walnut
AE	White 9010	JB	Bright Aluminium	QA	Maple
AK	Champagne	JC	Aluminium - Chrome	UT	T-Met 9007
AL	Ivory	JD	Matt Aluminium	UZ	T-Met
EA	Black	JE	Satin-finished Aluminium	WA	Bronzed
EB	Glossy Black	JF	Aluminium - Brass	WI	Burnished
EC	Matt Black	JG	Aluminium 5	XD	Satin-finished Steel
EE	Anthracite	JL	Aluminium PE 11	YA	Nickel-plated
EW	Grey 9007	JM	Aluminium RAL 9006	YB	Bright Nickel-plated
FU	Gunmetal	KA	Chrome	YC	Matt Nickel-plated
FV	Gunmetal V52	KB	Bright Chrome	YD	Satin-finished Nickel-plated
GR	Raw	KC	Matt Chrome	YQ	Black Nickel
HA	Brass-Plated	MA	Brown	Z9	Black Zinc
HH	Tropicalized	MB	Light Brown 1	ZA	Zinc alloy
HL	Raw Brass	NN	Metallic Beige	ZN	Zinc-plated
HX	Graphite	NO	Beige	ZQ	Bright Gold
IA	Grey	OA	Oak	ZY	Titanium
IB	Metallic Grey	OZ	Ash	ZZ	Clear
IF	Middle Grey	PA	Light Ash	00	Insignificant finish

PAD



18 mm min.



1 - Make Ø 8mm edge borings on the panel thickness using an appropriate template for driver-drill.

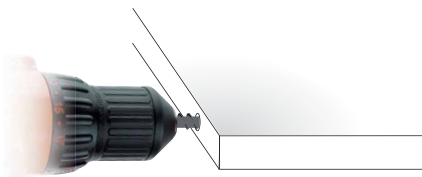

2 - Make Ø 5mm face borings on the other panel.



3 - Screw the assembly fitting into the face bored panel using a cross screwdriver.

Cross PZ2 screwdriver

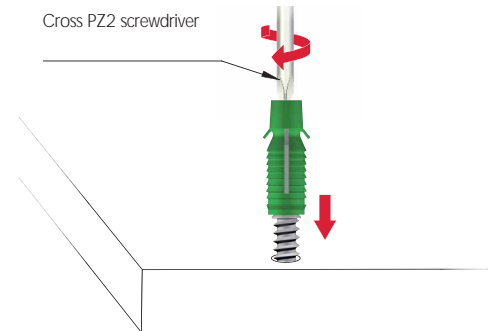

4 - Push manually the edge bored panel against the fitting until it is totally inserted.

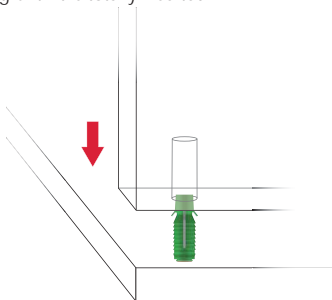

5 - The two panels will be permanently assembled without using any kind of glue.

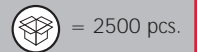
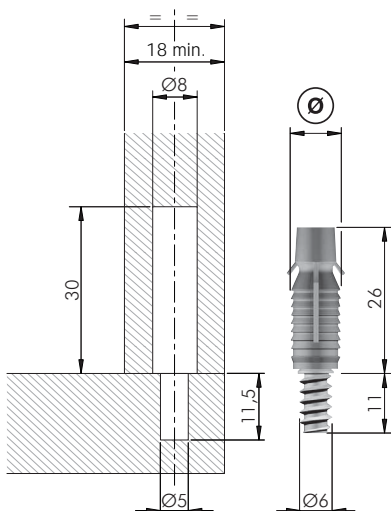
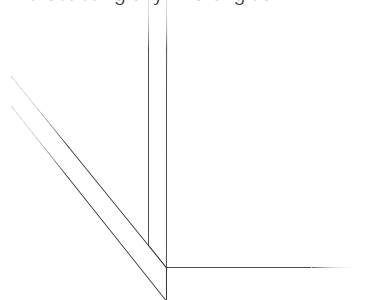

2162300000



9,3

2162301000

8,8

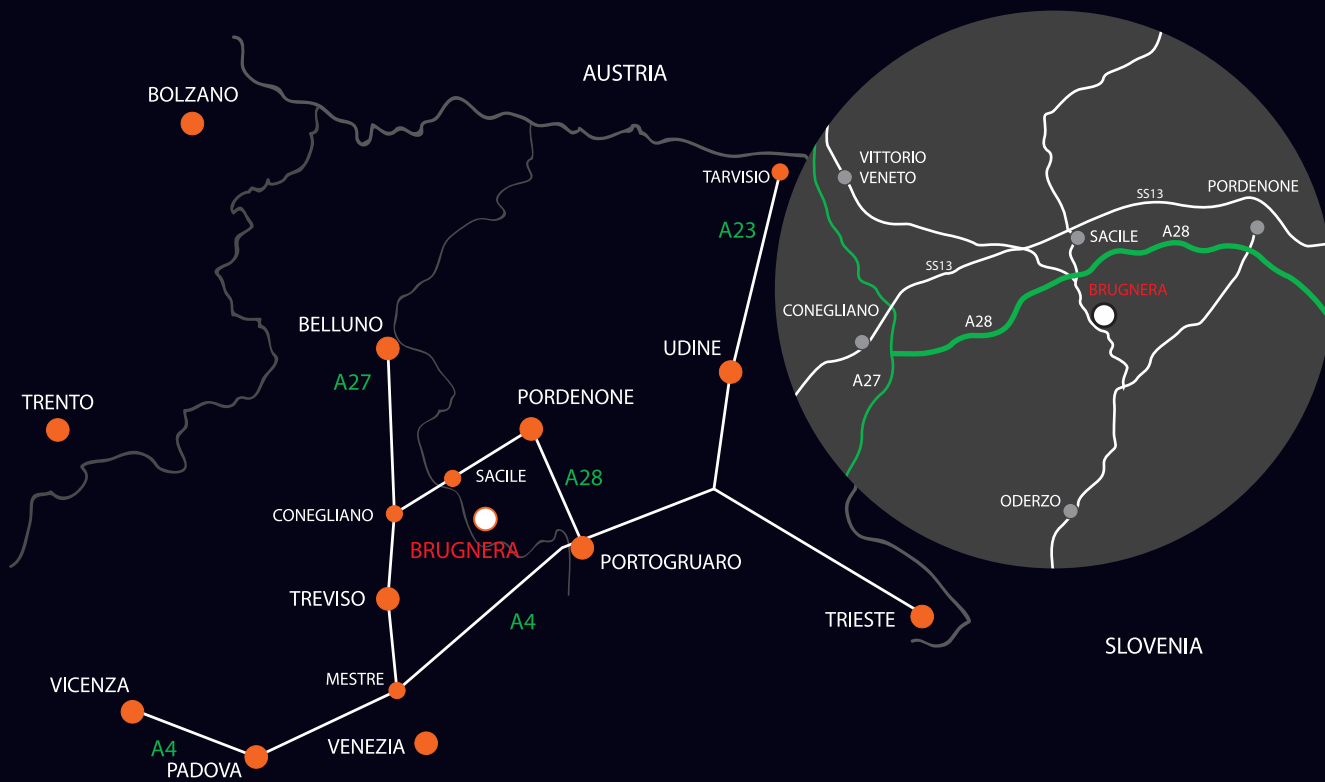

[www.italianaferramenta.com](http://www.italianaferramenta.com)